

**SPECIFICATIONS : ISOTECH EXPANSION JOINT  
CARBON STEEL PIPE WITH WELD END**

Model	Pressure Rating (PSI)	DIA (In)	'A' OAL (In)	'B' WIDTH (SQ.) (In)	RATED STROKE		WEIGHT (LBS)	QTY
					COMP. (In)	EXT. (In)		
IEJ-CS300-W2-0.75	300	0.75	10 ½	2	1 ½	½	2 ½	
IEJ-CS300-W2-1	300	1	10 ½	2	1 ½	½	2 ¾	
IEJ-CS300-W2-1.25	300	1 ¼	10 ½	2	1 ½	½	3 ¼	
IEJ-CS300-W2-1.5	300	1 ½	10 ½	2 ½	1 ½	½	4	
IEJ-CS300-W2-2	300	2	10 ½	3	1 ½	½	5 ¼	
IEJ-CS300-W2-2.5	300	2 ½	10 ½	3 ½	1 ½	½	7 ½	
IEJ-CS300-W2-3	300	3	10 ½	4 ½	1 ½	½	9 ½	
IEJ-CS300-W2-4	300	4	10 ½	5 ½	1 ½	½	10 ½	

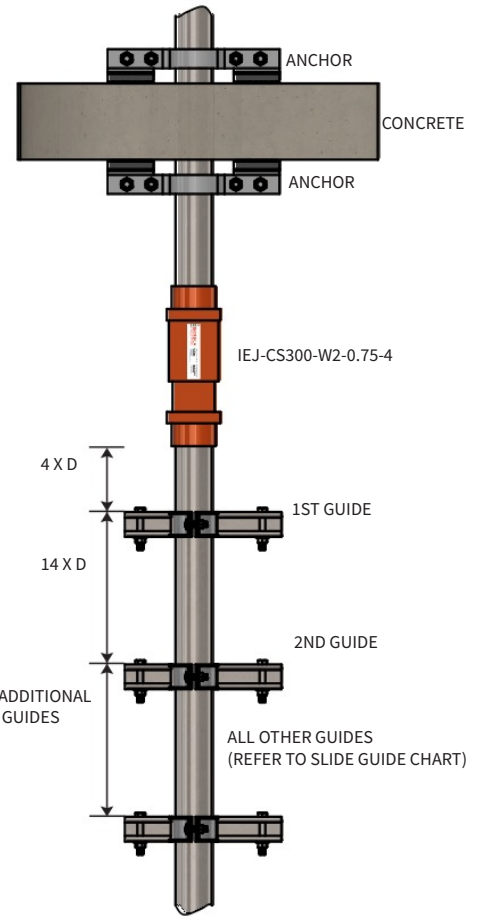

MATERIALS OF CONSTRUCTION	
SHROUD :	BRASS
BELLOWS :	316L STAINLESS STEEL
END FITTINGS :	CARBON STEEL

NOTE: END FITTINGS MAY BE 2 PIECE DESIGN USING COPPER  
DESIGN PRESSURE @ 70°F = 300 PSIG

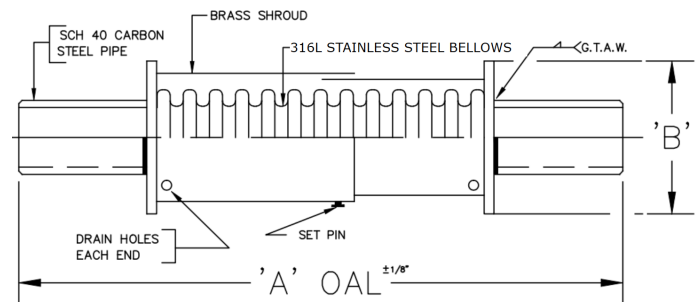
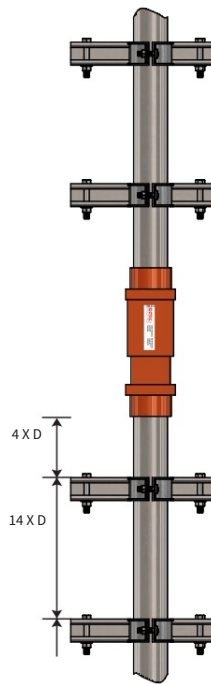

**IMPORTANT NOTE:**

1-EXPANSION COMPENSATOR'S ARE DESIGNED FOR A TOTAL OF 2" MOVEMENT; ACCOMMODATING 1 ½" PIPE THERMAL EXPANSION AND ½" PIPE THERMAL CONTRACTION.

PROJECT INFORMATION		EQUIPMENT INFORMATION		Canada location	USA Location
Customer:		Type:		35 Siltan Road Woodbridge ON L4L 7Z8 CANADA T: 905-856-5001	3021 E Coronado St. Anaheim, CA.,92806 U.S.A T: 949-788-2930
Project:		Qty Required:			
Drawing No:		Operating Weight:			
Notes:	Tool free : 1-888-831-3311 <a href="http://www.isotechindustries.com">www.isotechindustries.com</a>				