

BEFORE INSTALLATION:

Make sure the expansion joint rating for temperature, pressure, vacuum, movements and selection of EPDM materials match the system requirements. Contact ISOTECH if the system requirements exceed those of the flexible connection selected.

Vacuum Service for Spherical Rubber Connectors:

Vacuum rating is based on neutral installed length, without external load. These products should not be installed “extended” on vacuum applications.

Alignment:

Flexible Connections are not designed to make up for piping misalignment errors. Pipe misalignment should be no more than 1/8” in any direction. Misalignment of an expansion joint will reduce the rated movements and can induce severe stress of the material properties, thus causing reduced service life.

Pipe Support:

Piping must be supported so the Flexible Connections do not carry any pipe weight.

Mating Flanges:

1. Install the flexible connection against the mating pipe flanges and install bolts so that the bolt head is against the flexible connection flange. Flange to flange dimensions of the expansion joint must match the breach opening.
2. A spherical rubber connector must be compressed 1/8” to 3/16” during installation in order to obtain a correctly installed face to face dimension
3. Make sure mating flanges are clean and are flat faced type. When attaching beaded end flange Flexible Connections to raised face flanges, ring gaskets are required to prevent metal flange faces from cutting the rubber bead during installation.
4. Never install Flexible Connections next to wafer type check valves or butterfly valves. Serious damage to the rubber flange bead can result due to the lack of flange mating surface and or bolt connection.

IDS Bolt Torque Data:

This table shows the minimum recommended torque values for non-metallic Flexible Connections with beaded end type flanges to achieve an adequate seal.

BOLT TORQUE					
NORMAL PIPE SIZE	STEP 1	RESET	STEP 2	RESET	STEP 3
	Ft · Lbs.	MINUTES	Ft · Lbs.	MINUTES	Ft · Lbs.
1.5	18	30	30	60	45-60
2	18	30	30	60	45-60
2.5	18	30	35	60	50-60
3	25	30	45	60	60-75
3.5	25	30	45	60	60-75
4	25	30	45	60	60-75
5	25	30	45	60	60-75
6	30	30	50	60	60-75
8	30	30	50	60	60-75
10	30	30	50	60	75-85
12	30	30	50	60	75-85

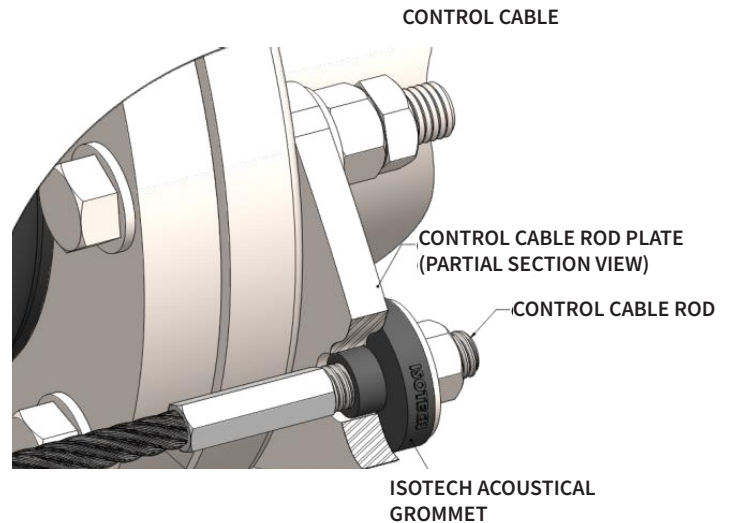

Tighten bolts in stages by alternating around the flange. Use the recommended torque values to achieve a good seal. Never tighten an expansion joint to the point that there is metal to metal contact between the expansion joint flange and the mating flange.

Note: Over-torquing bolts can cause deformation of the rubber expansion joint flanges, thus resulting in premature failure.

PROJECT INFORMATION		EQUIPMENT INFORMATION		Canada location	USA Location
Customer:		Type:		35 Silton Road Woodbridge ON L4L 7Z8 CANADA T: 905-856-5001	3021 E Coronado St. Anaheim, CA.,92806 U.S.A T: 949-788-2930
Project:		Qty Required:			
Drawing No:		Operating Weight:			
Notes:				Tool free : 1-888-831-3311 www.isotechindustries.com 	

Mating Flanges:

1. Store Flexible Connections in a dry, cool place, such as a warehouse.
2. Store flange face down on a pallet or wooden platform.
3. Do not store other heavy items on top of expansion joints.
4. Ten-year shelf life can be expected with ideal conditions.

Handeling:

5. Do not lift with ropes or bars through bolt holes. If lifting through the bore, use padding or a saddle to distribute the weight. Do not let Flexible Connections sit vertically on the edges of the flanges for any period of time.

Additional Tips:

1. Insulation over non-metallic rubber Flexible Connections is not recommended. However, if the insulation is required, it should be made removable to permit easy access to the flange area in order to check the bolting.
2. It is acceptable, but not necessary, to lubricate the expansion joint flanges with a thin film of graphite dispersed in glycerin or water to ease disassembly at a later time.
3. Do not weld in the vicinity of a non-metallic expansion joint.
4. If a flexible connection is to be installed outdoors, make sure the cover material will withstand ozone and environmental elements. Materials such as EPDM are recommended.
5. If the expansion joint is to be installed underground, or will be submerged in water, contact ISOTECH for specific guidelines.
6. Check the tightness of the retaining rings two or three weeks after installation and re-tighten as necessary after routine inspections.

Never install Flexible Connections next to wafer type check valves or butterfly valves. Serious damage to the rubber flange bead can result due to the lack of flange mating surface and or bolt connection.

Alignment:

Flexible Connections are not designed to make up for piping misalignment errors. Pipe misalignment should be no more than 1/8" in any direction. Misalignment of an expansion joint will reduce the rated movements and can induce severe stress of the material properties, thus causing reduced service life.

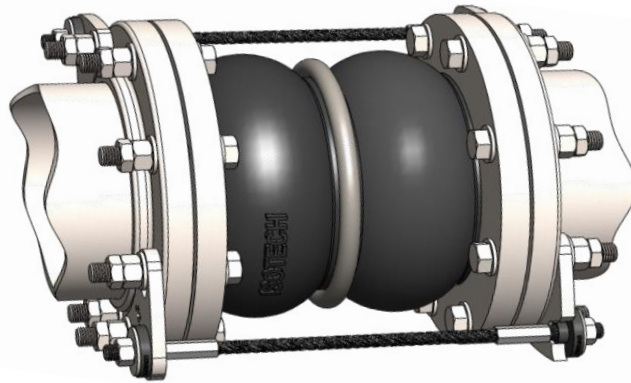

WARNING:

Flexible connections may operate in pipelines or equipment carrying fluids or gases at high temperatures and pressures. They may also transport hazardous materials. Precautions must be taken to protect personnel in the event of leakage or splash.

Rubber Flexible connections should not be installed in areas where inspection is impossible.

PROJECT INFORMATION		EQUIPMENT INFORMATION		Canada location	USA Location
Customer:		Type:		35 Silton Road Woodbridge ON L4L 7Z8 CANADA T: 905-856-5001	3021 E Coronado St. Anaheim, CA.,92806 U.S.A T: 949-788-2930
Project:		Qty Required:			
Drawing No:		Operating Weight:			
Notes:				Tool free : 1-888-831-3311 www.isotechindustries.com	

