

SPECIFICATIONS : ICSN-5R2, 5" DEFLECTION RESTRAINED SPRING ISOLATOR C/W (2) LAYERS OF ISOTECH VIBRATION ISOLATION PAD, ISOPAD-24

Model	Rated Load		Rated Deflection		Spring Color		Approx. WT.	
	lbf.	kN	in	mm	outer	inner	lbs.	kg
ICSN-5R2-200	200	0.89	5.0	127.0	ORANGE	---	164.00	74.39
ICSN-5R2-500	500	2.225	5.0	127.0	BLUE	---	166.00	75.30
ICSN-5R2-1000	1000	4.449	5.0	127.0	RED	---	169.00	76.66
ICSN-5R2-1500	1500	6.673	5.0	127.0	RED	YELLOW	169.00	76.66
ICSN-5R2-2000	2000	8.897	5.0	127.0	GREEN	---	171.00	77.56
ICSN-5R2-2500	2500	11.121	5.0	127.0	GREEN	YELLOW	170.00	77.11
ICSN-5R2-3000	3000	13.345	5.0	127.0	GREY	---	171.00	77.56
ICSN-5R2-3500	3500	15.569	5.0	127.0	BLACK	---	172.00	78.00
ICSN-5R2-4000	4000	17.793	5.0	127.0	BLACK	YELLOW	173.00	78.47
ICSN-5R2-4500	4500	20.017	5.0	127.0	WHITE	---	174.00	78.92
ICSN-5R2-5000	5000	22.793	5.0	127.0	BROWN	---	175.00	79.38

Model											
DIMENSION : ICSN-5R2-200-5000 WITH (2) LAYERS OF ISOTECH VIBRATION ISOLATION PAD, ISOPAD-24											
L		W		W1		H		T		W2	
in	mm	in	mm	in	mm	in	mm	in	mm	in	mm
18.0	458	9.0	229	6 1/2	165	14 15/16	379	5/8	16	5.0	127
ø D		ø d		M		N		a		SPRING ADJUSTMENT BOLTS	
in	mm	in	mm	in	mm	in	mm	in	mm		
1 3/16	21	1 1/16	18	5.0	13	1 1/4	32	2	51	1"	

ISOLATOR'S LOCATIONS	
1:	5:
2:	6:
3:	7:
4:	8:

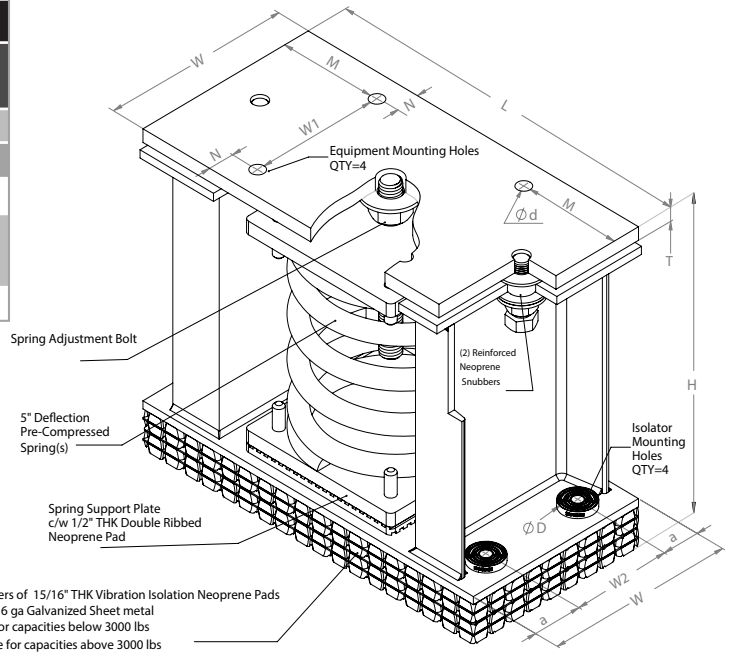
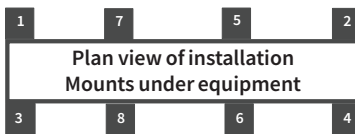

Notes:

- ICSN-5R2-200-5000 Isolators are all Pre-Compressed to allow the lowest overall installation height and to offer significant labor saving during installation
- All springs have additional travel to solid equal to 50% of the Rated Deflection with minimum Kx/Ky ratio of 1.0 - All Elements are safe at solid load
- Spring(s) are powder - coated to provide maximum corrosion resistance , and are color-coded for easy identification at site - see table above
- Powder-coated finish for Housing Spring Compression Plate and Spring Support Plate to offer maximum corrosion resistance for isolator - Hardware are zinc electroplated
- ICSN-5R2-200-5000 isolators are designed to allow replacement of Reinforced Snubber without disturbing equipment. Reinforced Snubbers are installed to prevent metal to metal contact
- Same thickness plate, with the same dimensions of isolator top plate, must be installed on top of isolator, when less than 80% of isolator's top plate is covered

PROJECT INFORMATION		EQUIPMENT INFORMATION		Canada location	USA Location
Customer:		Type:		35 Siltan Road Woodbridge ON L4L 7Z8 CANADA T: 905-856-5001	3021 E Coronado St. Anaheim, CA, 92806 U.S.A T: 949-788-2930
Project:		Qty Required:			
Drawing No:		Operating Weight:			
Notes:				Tool free : 1-888-831-3311 www.isotechindustries.com	



SPECIFICATIONS : ACOUSTICAL GROMMET WASHER IGR-XX

Model	øA		øB		øC		H		T		T1	
	in	mm	in	mm	in	mm	in	mm	in	mm	in	mm
IGR-38	3/8	10	1/2	13	1 1/4	32	1/2	13	1/4	7	1/8	4
IGR-50	1/2	13	3/4	20	1 5/8	42	5/8	16	5/16	8	3/16	5
IGR-63	5/8	16	7/8	23	2	51	3/4	20	3/8	10	3/16	5

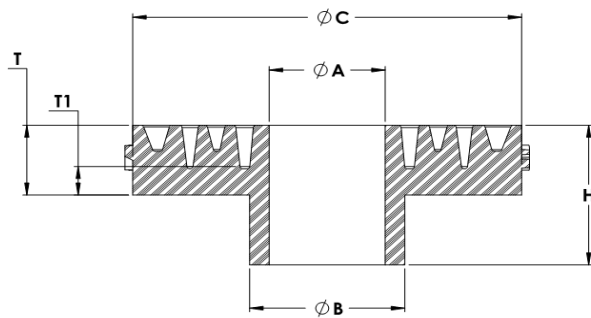

IGR - XX Section View

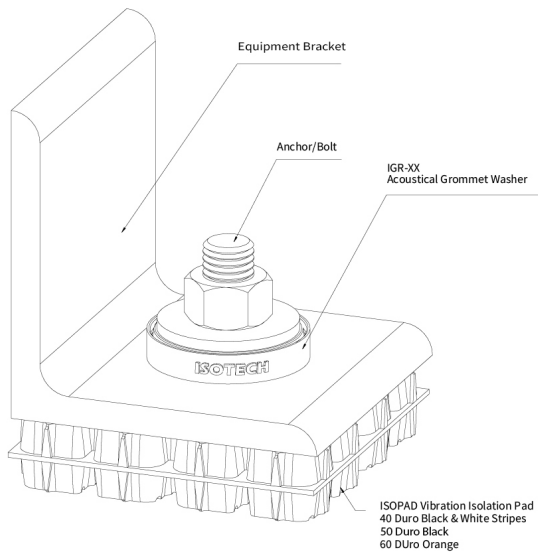

Notes:

- Application of grooves and thicker material offers significant improvements on isolation efficiency of the system
- IGR Acoustical Grommet is available on 50 & 60 Duro Neoprene Material
- IGR Acoustical Grommet neoprene material is per ASTM D2000 Standards
- Anchor or bolt size to match øA dimension
- Deflection-Load graphs are based on 60 Duro Neoprene Material

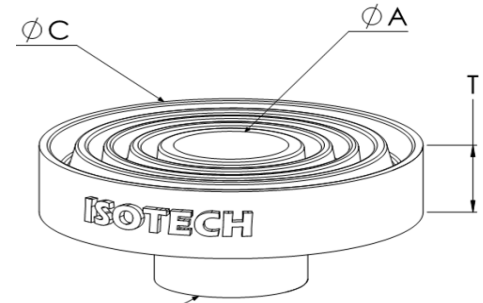

IGR-38

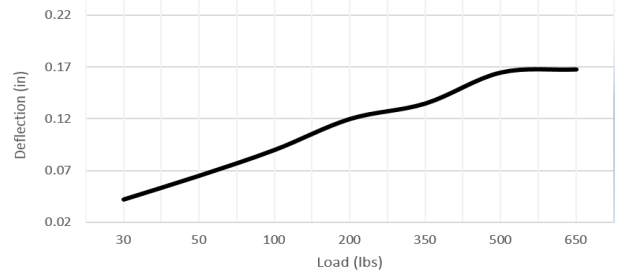

IGR-50

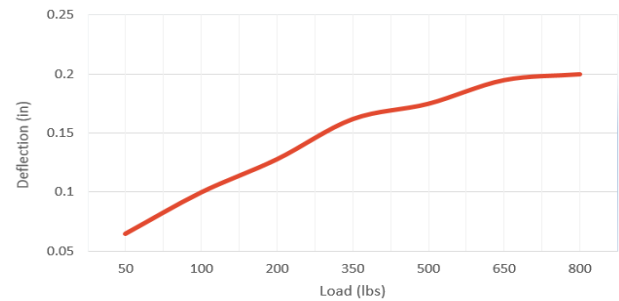

IGR-63

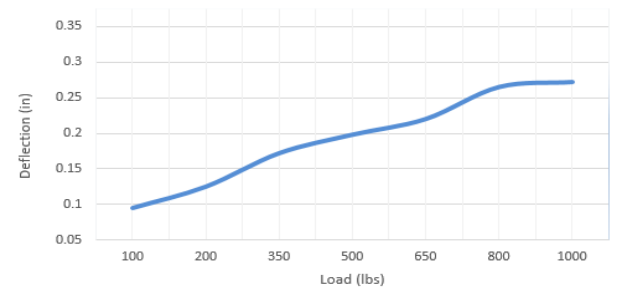

PROJECT INFORMATION		EQUIPMENT INFORMATION		Canada location	USA Location	
Customer:		Type:		35 Silton Road Woodbridge ON L4L 7Z8 CANADA T: 905-856-5001	3021 E Coronado St. Anaheim, CA.,92806 U.S.A T: 949-788-2930	
Project:		Qty Required:				
Drawing No:		Operating Weight:				
Notes:					Tool free: 1-888-831-3311 www.isotechindustries.com	



ISOPAD-24 ISOTECH VIBRATION ISOLATION PAD

File No. : ISOPAD-24

Date: 03/29/22

ISOIN-ISOPAD-24, Installation Instructions document, to be Reviewed for Installation

ISOPAD 40 Duro Black with White Stripes								
ISOPAD-X-40	x		Load range		Optimum load		Approx. WT.	
	in	mm	lb.	kN	lb.	kN	lbs.	kg
	2.0	50	40 - 180	0.176 - 0.79	120	0.53	0.09	0.05
3.0	75	90 - 405	0.396 - 1.78	270	1.20	0.21	0.1	
4.0	100	160 - 720	0.704 - 3.17	480	2.14	0.38	0.18	
6.0	150	360 - 1620	1.584 - 7.13	1080	4.81	0.84	0.39	
9.0	225	810 - 3645	3.564 - 16.04	2430	10.81	1.93	0.88	
12.0	300	1440 - 6480	6.336 - 28.51	4320	19.22	3.38	1.54	
18.0	450	3240 - 14580	14.256 - 64.15	9720	43.24	3.38	1.54	
24.0	600	5760 - 25920	25.344 - 114.05	17280	76.87	13.50	6.13	

ISOPAD 50 Duro Black								
ISOPAD-X-50	X		Load range		Optimum load		Approx. WT.	
	in	mm	lb.	kN	lb.	kN	lbs.	kg
	2.0	50	80 - 280	0.352 - 1.23	180	0.80	0.10	0.05
3.0	75	180 - 630	0.792 - 2.77	405	1.80	0.23	0.11	
4.0	100	320 - 1120	1.408 - 4.93	720	3.20	0.40	0.19	
6.0	150	720 - 2520	3.168 - 11.09	1620	7.21	0.91	0.42	
9.0	225	1620 - 5670	7.128 - 24.95	3645	16.21	2.07	0.94	
12.0	300	2880 - 10080	12.672 - 44.35	6480	28.83	3.63	1.65	
18.0	450	6480 - 22680	28.512 - 99.79	14580	64.86	3.63	1.65	
24.0	600	11520 - 40320	50.688 - 177.41	25920	115.30	14.50	6.58	

ISOPAD 60 Duro Orange								
ISOPAD-X-60	X		Load range		Optimum load		Approx. WT.	
	in	mm	lb.	kN	lb.	kN	lbs.	kg
	2.0	50	160 - 420	0.704 - 1.85	320	1.42	0.11	0.05
3.0	75	360 - 945	1.584 - 4.16	720	3.20	0.24	0.11	
4.0	100	640 - 1680	2.816 - 7.39	1280	5.69	0.43	0.2	
6.0	150	1440 - 3780	6.336 - 16.63	2880	12.81	0.97	0.44	
9.0	225	3240 - 8505	14.256 - 37.42	6480	28.83	2.21	1.01	
12.0	300	5760 - 15120	25.344 - 66.53	11520	51.24	3.88	1.76	
18.0	450	12960 - 34020	57.024 - 149.69	25920	115.30	8.61	3.91	
24.0	600	23040 - 60480	101.376 - 266.11	46080	204.97	15.50	7.04	

Thickness		Deflection Range		Optimum Deflection	
in	mm	in	mm	in	mm
15/16	24.0	0.08 To 0.26	2.0 to 6.4	0.21	5.3

Notes:

- Full size pad is 24"x 24" x 15/16" (600 x 600 x 24mm) - a total of 144 - 2" modules
- Pad is designed to have thin web between modules that allows quick and easy cut with utility knife on site.
- 24" x 24" pad size offers minimum waste on site and provides evenly dimensioned pads such as 2" x 2" (50 x 50mm), 2" x 4" (50 x 100mm), 4" x 4" (100 x 100mm)
- Pads are made of high quality AASHTO Bridge-Bearing Neoprene material for maximum life service, excellent oil resistance and vibration isolation performance.
- ISOPAD-24 is available in 40 Duro- Color coded Black with White stripes - 50 Duro Black and 60 Duro Orange. Review table and graph for safe design and performance
- Pads can be stacked with 16 ga (1.5mm) Galvanized sheet metal to increase deflection and isolation efficiency. When two layers are laminated, they can provide double the deflection under the same load as shown in table and graph.

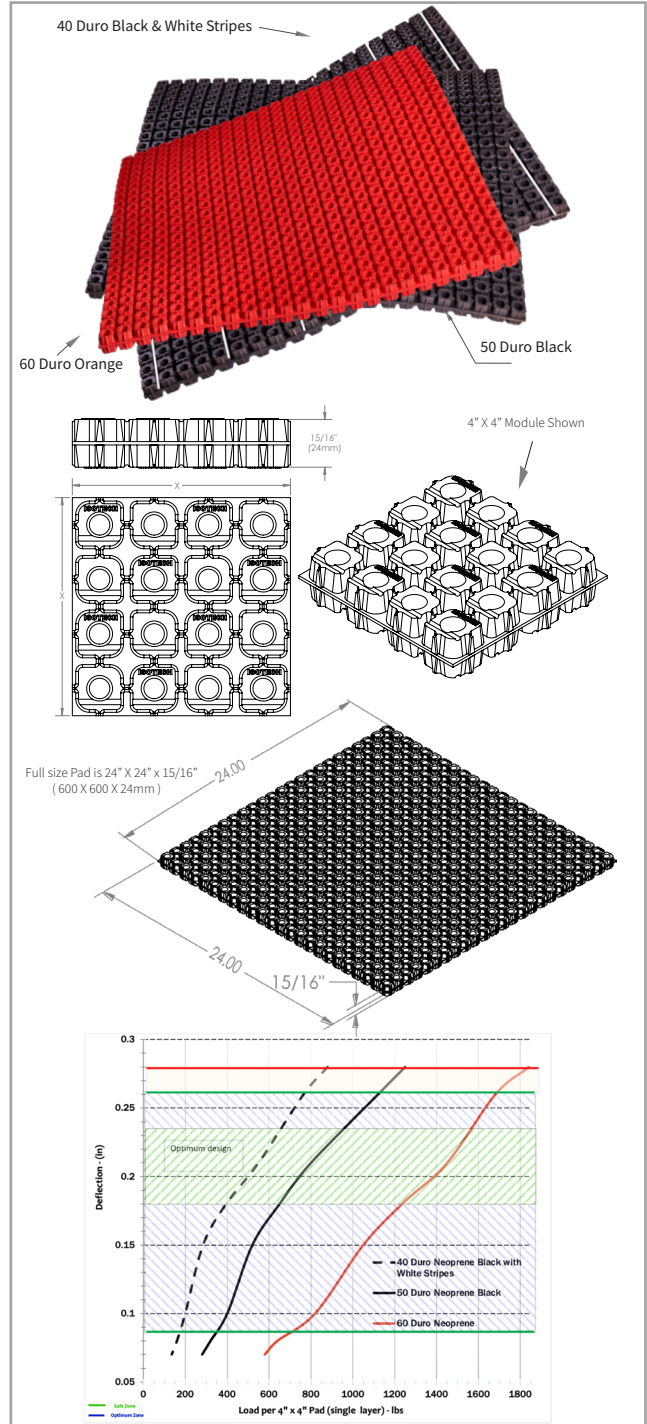

Mark this Box if distribution plate is required. Product code ISOPAD-XM

PROJECT INFORMATION		EQUIPMENT INFORMATION		Canada location	USA Location
Customer:		Type:		35 Silton Road Woodbridge ON L4L 7Z8 CANADA T: 905-856-5001	3021 E Coronado St. Anaheim, CA, 92806 U.S.A T: 949-788-2930
Project:		Qty Required:			
Drawing No:		Operating Weight:			
Notes:					

Tool free : 1-888-831-3311
www.isotechindustries.com

