

SPECIFICATIONS - 2" DEFLECTION SPRING HANGER

Model	RATED LOAD		RATED DEFLECTION		SPRING COLOR	APPROX. WT.	
	Lbs.	KN	in	mm		Lbs.	Kg
IHA-1-30	30	0.134	1	25.4	YELLOW	1.60	0.73
IHA-1-50	50	0.223	1	25.4	GREEN	1.60	0.73
IHA-1-100	100	0.445	1	25.4	BLACK	1.70	0.78
IHA-1-150	150	0.668	1	25.4	RED	1.70	0.78
IHA-1-200	200	0.89	1	25.4	BLUE	1.80	0.82
IHA-1-300	300	1.335	1	25.4	WHITE	1.90	0.87
IHA-1-400	400	1.78	1	25.4	BROWN	2.05	0.93
IHA-1-500	500	2.225	1	25.4	ORANGE	2.10	0.96
IHA-1-600	600	2.669	1	25.4	GREY	2.20	1

HARDWARE NOT INCLUDED - SPRING CUP : ZINC PLATED

Dimension

2" DEFLECTION SPRING HANGER - MODEL IHA

Model	H		W		L	
	in	mm	in	mm	in	mm
IHA-1-30-600	5 3/4	147	2 5/8	67	2 1/2	64

Notes:

- Housing is designed to allow 30° misalignment for hanger rod
- Neoprene Element is designed to provide up to 0.35" deflection at rated load
- Springs are powder – coated for maximum corrosion protection, and are designed to have minimum 50% over travel

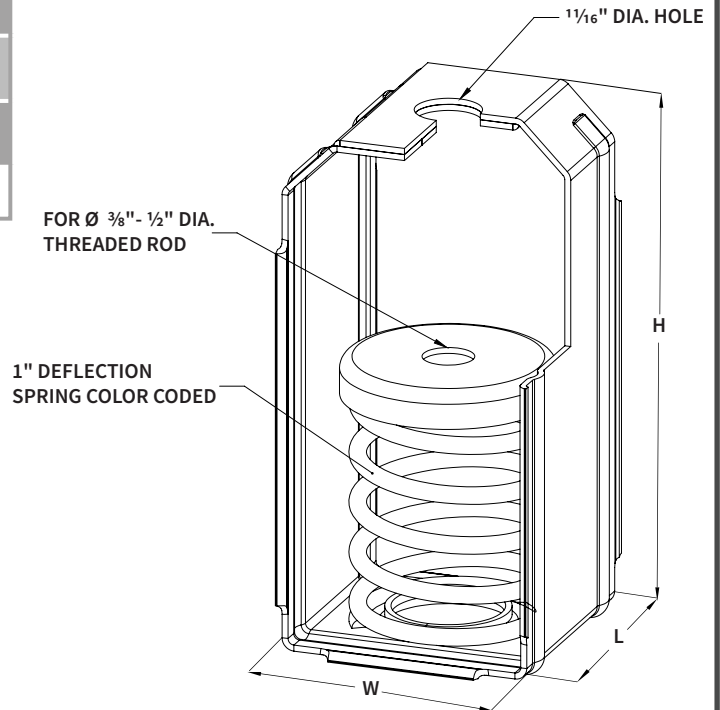

PROJECT INFORMATION		EQUIPMENT INFORMATION		Canada location	USA Location	
Customer:		Type:		35 Silton Road Woodbridge ON L4L 7Z8 CANADA T: 905-856-5001	7700 Irvine Centre Drive Suite 800 Irvine, CA, 92618 U.S.A T: 949-788-2930	
Project:		Qty Required:				
Drawing No:		Operating Weight:				
Notes:				www.isotechindustries.com		