

SPECIFICATIONS - ACOUSTICAL GROMMET WASHER MODEL IGR-XX

Model	øA		øB		øC		H		T		T1	
	in	mm	in	mm	in	mm	in	mm	in	mm	in	mm
IGR-38	3/8	10	1/2	13	1 1/4	32	1/2	13	1/4	7	1/8	4
IGR-50	1/2	13	3/4	20	1 5/8	42	5/8	16	5/16	8	3/16	5
IGR-63	5/8	16	7/8	23	2	51	3/4	20	3/8	10	3/16	5

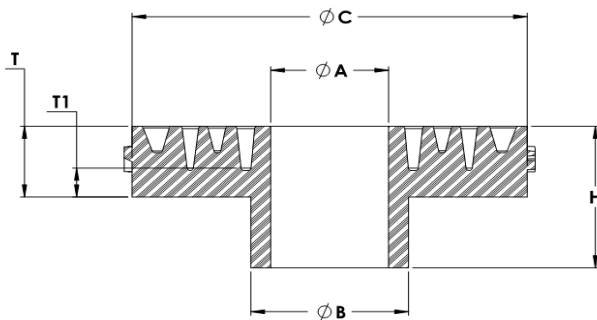

IGR - XX Section View

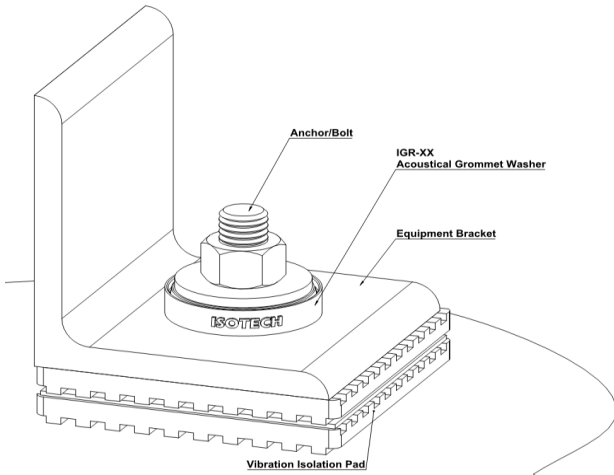

Notes:

- Application of grooves and thicker material offers significant improvements on isolation efficiency of the system
- IGR Acoustical Grommet is available on 50 & 60 Duro Neoprene Material
- IGR Acoustical Grommet neoprene material is per ASTM D2000 Standards
- Anchor or bolt size to match øA dimension
- Deflection-Load graphs are based on 60 Duro Neoprene Material

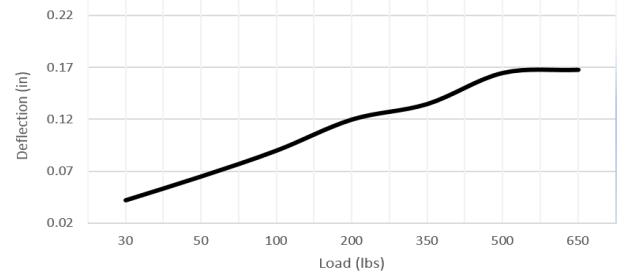
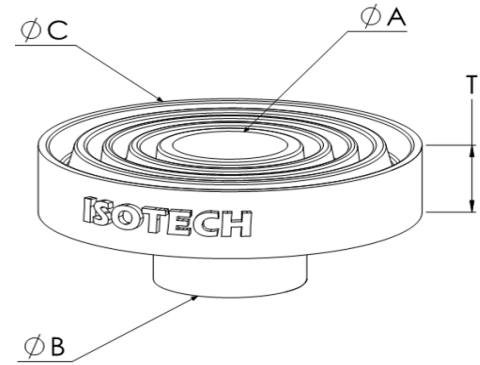

IGR-50

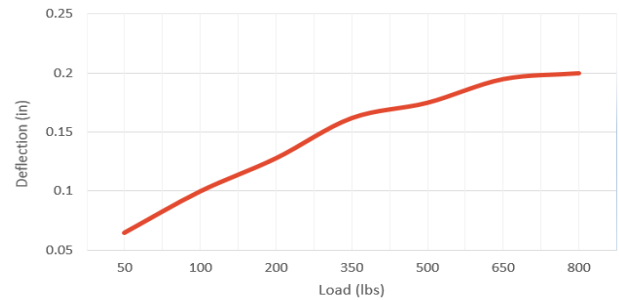

IGR-63

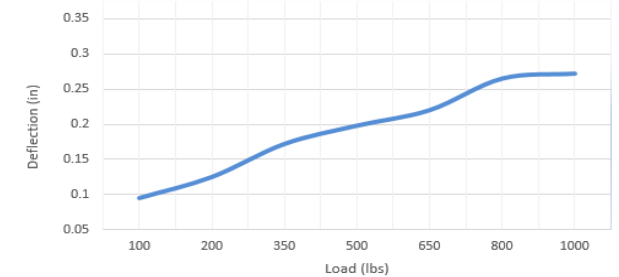

PROJECT INFORMATION		EQUIPMENT INFORMATION		Canada location	USA Location	
Customer:		Type:		35 Silton Road Woodbridge ON L4L 7Z8 CANADA T: 905-856-5001	7700 Irvine Centre Drive Suite 800 Irvine, CA, 92618 U.S.A T: 949-788-2930	
Project:		Qty Required:				
Drawing No:		Operating Weight:				
Notes:				www.isotechindustries.com		